

2"-12"

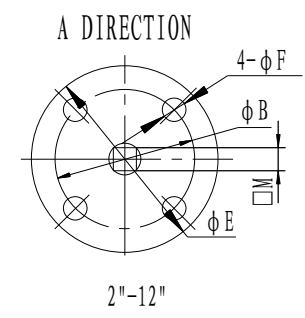
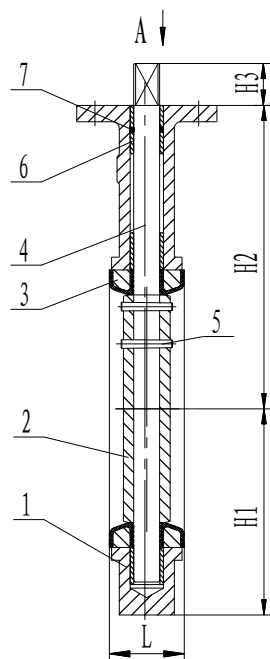

UNIT: mm

DN	INCH	H1	H2	H3	L	φC	n-φ	φE	φB	φF	□M	ISO
50	2"	76	162	30	44.5	120.5	4-φ19	90	70	10	9	F07
65	2.5"	83	173	30	47.5	139.5	4-φ19	90	70	10	9	F07
80	3"	95	181	30	47.5	152.5	4-φ19	90	70	10	9	F07
100	4"	114	200	30	54	190.5	8-φ19	90	70	10	11	F07
125	5"	123	213	30	57	216	8-φ22	90	70	10	14	F07
150	6"	136	225	30	57	241.5	8-φ22	90	70	10	14	F07
200	8"	181	260	36	63.5	298.5	8-φ22	125	102	12	17	F10
250	10"	209	292	36	70	362	12-φ25	125	102	12	22	F10
300	12"	240	335	36	79	432	12-φ25	125	102	12	22	F10

7	O-RING	BUNA	
6	BUSHING	PTFE	
5	TAPER PIN	SS316	
4	STEM	SS416	
3	SEAT	BUNA-N	
2	DISC	DI	
1	BODY	DI	
NO.	PARTS NAME	MATERIAL	
TEST PRESSURE		SHELL	SEAL
	HYDROSTATIC	300PSI	220PSI
	AIR		
STANDARD	INSPECTION & TEST	API598	
	END STANDARD	ANSIB16.1 CLASS150	
	DESIGN	API609	
TITLE: WAFER BUTTERFLY VALVE		2"-12"	